



ISO 9001



Actuators

for air dampers and control valves of oil burners

SQM1... SQM2...

Reversible electromotoric actuators

- **Torques:**
 - SQM1... up to 10 Nm
 - SQM2... up to 20 Nm
- **Run times:**
 - SQM1... 14...100 s
 - SQM2... 29...66 s
- **Versions:**
 - Clockwise or counterclockwise rotation

The SQM... and this Data Sheet are intended for use by OEMs which integrate the actuators in their products!

Use

The reversible actuators of the SQM... range are for use in connection with controllers or switching devices equipped with changeover contacts.

Warning notes



To avoid injury to persons, damage to property or the environment, the following warning notes should be observed!

Only qualified staff may open, interfere with or modify the actuators!

- Before performing any wiring changes in the connection area of the actuator, completely isolate the equipment from the mains supply (all-polar disconnection)
- Ensure protection against electric shock hazard by providing adequate protection for the terminals
- Check to ensure that wiring is in an orderly state
- Fall or shock can adversely affect the safety functions. Such units may not be put into operation, even if they do not exhibit any damage

Mounting notes

- Ensure that the relevant national safety regulations are complied with
- When mounting actuator and damper linkage, the geartrain can be disengaged with a lever, thus allowing the actuator's drive shaft to be easily adjusted in either direction of rotation

Installation notes

- Installation work must be carried out by qualified staff

Commissioning notes

- Commissioning work must be carried out by qualified staff
- Prior to commissioning, ensure that wiring is in an orderly state

Norms and standards

Conformity to EEC directives	
- Electromagnetic compatibility EMC (immunity)	89 / 336 EEC
- Low-voltage directive	73 / 23 EEC

Service notes

- Maintenance work must be carried out by qualified staff
- Each time a unit has been replaced, check to ensure that wiring is in an orderly state

Disposal notes



The actuator contains electrical and electronic components and may not be disposed of together with household waste.
Local and currently valid legislation must be observed.

Mechanical design

Housing	<ul style="list-style-type: none">- The actuator's cover is made of impact-proof and heat-resistant plastic. Color: Dark-grey- The housing of the geartrain is made of die-cast aluminium and has 4 threaded holes for cable glands Pg11
Actuator	<ul style="list-style-type: none">- Reversible, locking-proof synchronous motor
Adjustment of switching points	<ul style="list-style-type: none">- With adjustable cams- Setting scales beside the cams give the switching point's angular position- The other cams can be adjusted manually, either with the enclosed hook spanner or tool
Position indicator	<ul style="list-style-type: none">- Internally: Scale at the beginning of the cam stack on the geartrain side- Only SQM21...: Equipped with position indicator visible from outside (also refer to «Dimensions»)
Electrical connections	<ul style="list-style-type: none">- Screw terminals
Geartrain	<ul style="list-style-type: none">- The reduction gearing has self-lubricating sinter-bronze bearings and requires no maintenance
Drive shaft	<ul style="list-style-type: none">- Ready fitted to the front of the geartrain
Mounting and fixing	<ul style="list-style-type: none">- Geartrain front is used as the mounting surface- Fixing by means of 3 threaded holes M5

SQM 10 . 1 5 5 0 2 x x Serie 03

781201e/0303

Voltage / frequency:
 1 AC 110 V / 50...60 Hz
 2 AC 220...240 V / 50 Hz bzw. AC 220 V / 60 Hz
 A87 DC 24 V / 60 Hz

Connection diagram:
 0 H 4 318 1521 0 Nr. 1 (refer to "Internal diagram")
 3 H 4 318 1521 0 Nr. 1 (refer to "Internal diagram")
 6 H 4 318 1522 0 Nr. 2 (refer to "Internal diagram")

Number of auxiliary switches:
 5 5 auxiliary switches
 1 1 auxiliary switch

Run time:
 90°- 130°-angular rotation
 5 14 s 20 s
 6 29 s 42 s
 7 70 s 100s
 8 45 s 66 s

Motor
 Direction of rotation (facing the drive shaft):
 0 Counterclockwise
 1 Clockwise

Torque:
 1 Standard 10 Nm
 2 Heavy duty 20 Nm

Type summary

Run time 50 Hz ¹⁾ for angular rotation	³⁾	Direction of rotation when facing the drive shaft and with control voltage applied to terminal 1	Number of auxiliary switches	Nominal torque ²⁾	Start- ing torque	Hold- ing torque	For AC 220...240 V 50 Hz or AC 220 V 60 Hz ⁴⁾	For AC 110 V 50 Hz or AC 110 V 60 Hz (on request) ⁴⁾
90°	130°						Type reference	Type reference
Standard version, diameter of drive shaft 10 mm								
14 s	20 s	1	Counterclockwise	5	10 Nm	10 Nm	4 Nm	SQM10.15502 ---
14 s	20 s	2	Counterclockwise	5	10 Nm	10 Nm	4 Nm	SQM10.15562 SQM10.15561
29 s	42 s	1	Counterclockwise	1	10 Nm	15 Nm	7 Nm	SQM10.16102 ---
29 s	42 s	1	Counterclockwise	5	10 Nm	15 Nm	7 Nm	SQM10.16502 ---
29 s	42 s	1	Counterclockwise	5	10 Nm	15 Nm	7 Nm	SQM10.16532 ---
29 s	42 s	2	Counterclockwise	5	10 Nm	15 Nm	7 Nm	SQM10.16562 SQM10.16561
70 s	100s	1	Counterclockwise	5	10 Nm	15 Nm	15 Nm	SQM10.17502 ---
29 s	42 s	1	Clockwise	5	10 Nm	15 Nm	7 Nm	SQM11.16502 ---
Heavy duty version								
Diameter of drive shaft 12 mm								
Geartrain shafts made of hardened steel, gearwheels nitrated								
Type SQM21... with external position indication (refer to «Dimensions»)								
29 s	42 s	1	Counterclockwise	5	20 Nm	20 Nm	12 Nm	SQM20.16502 ---
45 s	66 s	1	Counterclockwise	5	20 Nm	20 Nm	12 Nm	SQM20.18502 ---
29 s	42 s	1	Clockwise	5	20 Nm	20 Nm	12 Nm	SQM21.16502 ---
45 s	66 s	1	Clockwise	5	20 Nm	20 Nm	12 Nm	SQM21.18502 SQM21.18501

- 1) At 60 Hz, run times are about 17 % shorter
- 2) Based on 150,000 position changes
- 3) Wiring according to diagram no.
- 4) Additional types on request

Ordering

When ordering, please give type references of actuator and accessories according to «Type summary».

In addition to the actuator, the following item is to be ordered separately; it is also supplied separately:

- Changeover relay ASZ50.5

Accessories

Changeover relay

ASZ50.5

– For single-wire control of SQM10... / SQM20...

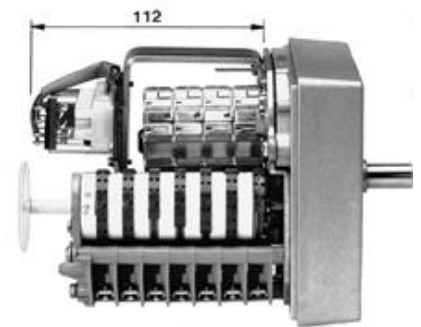
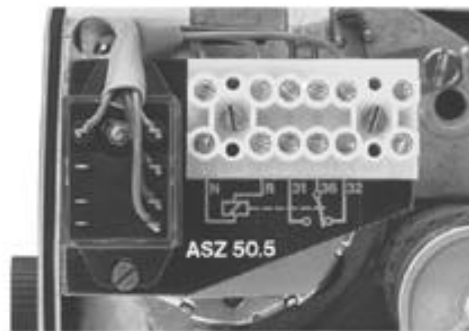

Potentiometer ASZ...

Refer to Data Sheet 7921

- For integration on site

Technical data

General actuator data	Operating voltage		
	- At 50 Hz ± 6 %	AC 220 V -15 %...AC 240 V $+10$ %	
	- At 60 Hz ± 6 %	AC 220 V -15 % / $+10$ % (AC 110 V versions on request)	
	Switching capacity of end and auxiliary switches	10 (3) A, AC 24...250 V	
	Positioning angle	up to 160° (scale range)	
	Mounting position	optional	
	Safety class	I	
	Degree of protection	IP 54, DIN 40050 (provided cable entry is adequate and holes not used are closed off)	
	Cable entry M16 and M20	for 2 x M16 x 1.5 and 2 x M20 x 1.5	
	Weight	approx. 1.7 kg	
	Type of motor	synchronous motor	
	Power consumption	9 VA	
	Environmental conditions	Transport	DIN EN 60 721-3-2
		Climatic conditions	class 2K2
Mechanical conditions		class 2M2	
Temperature range		$-50...+60$ °C	
Humidity		< 95 % r.h.	
Operation		DIN EN 60 721-3-3	
Climatic conditions		class 3K5	
Mechanical conditions		class 3M2	
Temperature range (switch on ratio < 0.5)		$-20...+60$ °C	
Humidity		< 95 % r.h.	



Condensation, formation of ice and ingress of water are not permitted!

Function

The synchronous motor drives the shaft via the geartrain. Attached to the drive shaft is a cam stack which actuates the end and auxiliary switches. The switching position of each end and auxiliary switch can be adjusted within the operating range with the help of the relevant cams.

The control section includes 2 end switches and a maximum of 5 auxiliary switches. In addition, a potentiometer can be integrated (as a feedback potentiometer for P-control, or as a setting unit for slave control, or for remote position indication).

Internal diagrams

SQM...

Diagram no. 1 (H 4 318 1521 0)

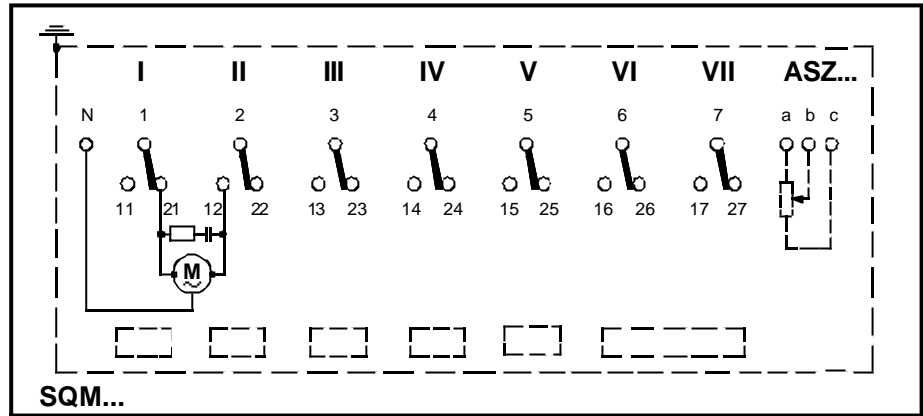

7812a01/1097

Diagram no. 2 (H 4 318 1522 0)

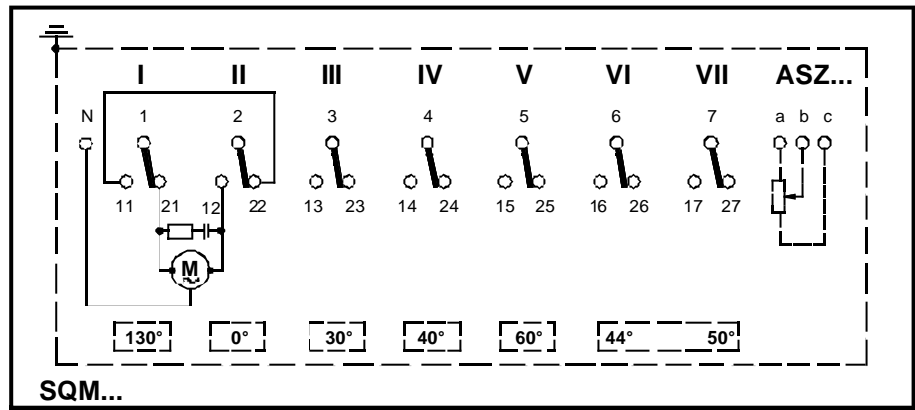

7812a02/1097

ASZ50.5

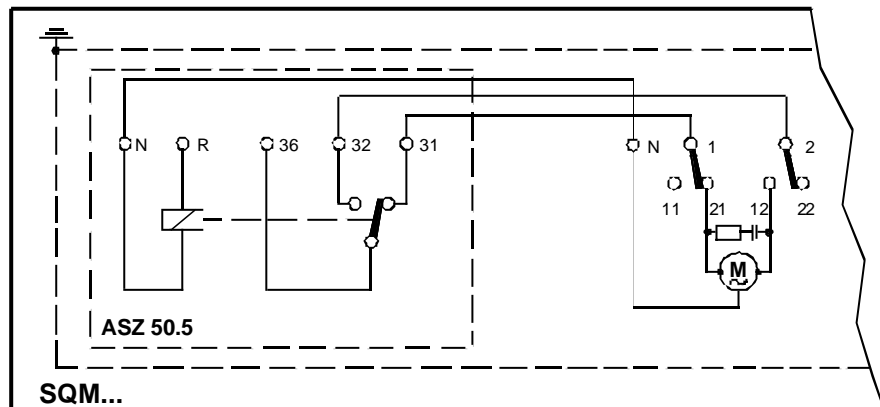

7812a03/1097

Dimensions

Dimensions in mm

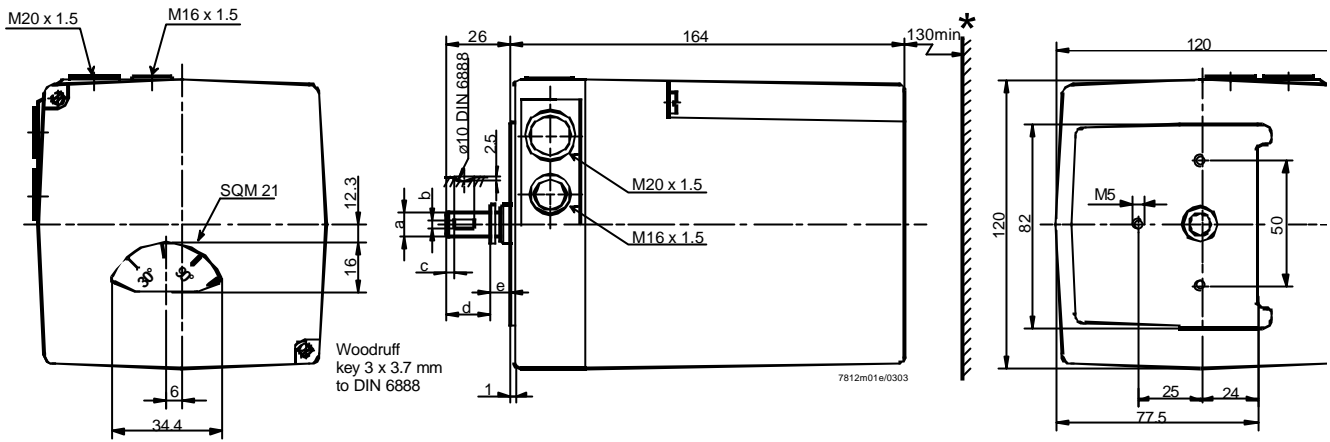

* Clearance required to remove the cover

Type reference	a	b	c	d	e
SQM1...	10h8	3 ^{N9}	4	20	6
SQM2...	12h8	3 ^{N9}	4	21.5	4.5

The groove on the actuator's drive shaft is in the position shown when the cam stack is in the 0° position (as supplied).